

# Rapporti tecnici

# INGV

**The MSG-SEVIRI off line Data Processor:  
Exploring HRIT Archived Data**

# 160



## **Direttore**

Enzo Boschi

## **Editorial Board**

Raffaele Azzaro (CT)

Sara Barsotti (PI)

Mario Castellano (NA)

Viviana Castelli (BO)

Rosa Anna Corsaro (CT)

Luigi Cucci (RM1)

Mauro Di Vito (NA)

Marcello Liotta (PA)

Simona Masina (BO)

Mario Mattia (CT)

Nicola Pagliuca (RM1)

Umberto Sciacca (RM1)

Salvatore Stramondo (CNT)

Andrea Tertulliani - Editor in Chief (RM1)

Aldo Winkler (RM2)

Gaetano Zonno (MI)

## **Segreteria di Redazione**

Francesca Di Stefano - coordinatore

Tel. +39 06 51860068

Fax +39 06 36915617

Rossella Celi

Tel. +39 06 51860055

Fax +39 06 36915617

[redazionecen@ingv.it](mailto:redazionecen@ingv.it)



# Rapporti tecnici INGV

## **THE MSG-SEVIRI OFF LINE DATA PROCESSOR: EXPLORING HRIT ARCHIVED DATA**

Massimo Musacchio, Malvina Silvestri, Maria Fabrizia Buongiorno

INGV (Istituto Nazionale di Geofisica e Vulcanologia, Sezione Centro Nazionale Terremoti)

# 160



## Index

Introduction .....	5
1. The MSG – SEVIRI data processor description .....	5
2. Data processor overall description .....	6
3. Archives decompression .....	6
4. Co-registration .....	7
Conclusions .....	9
Acknowledgements .....	10
References .....	11



## Introduction

In the frame work of the European Space Agency funded project (ESA Contract: n° 19494/05/IL-G), a processor dedicated to the processing of offline Meteosat Second Generation - Spinning Enhanced Visible & Infra Red Imager (MSG-SEVIRI) data has been developed. This processor has the capability to ingest the High Rate Information Transmission data (HRIT) format, uncompressing and processing the Earth Observation Earth Observed (EO) data generating co-registered dataset composed by 11 channel organized in Hierarchical Data Format HDF format.

During the activities performed in the above ESA contract, it has been decided to develop this processor enabling the capacity to process archived data and at the same time to re-process raw data acquired by the SEVIRI antenna, recently (2010) installed at Istituto Nazionale di Geofisica e Vulcanologia headquarters (INGV) in Rome.

This software (SW) ingests data characterized by the same acquisition rate of Real Time (RT) processor developed by external provider and generates output files with the same time rate; this means that it is able to produce a co-registered and calibrated data every 15 minutes.

### 1. The MSG – SEVIRI data processor description

The Meteosat Second Generation (MSG) satellites produce Spinning Enhanced Visible & InfraRed Imager (SEVIRI) image data in the form of both High and Low Rate SEVIRI image data. These real-time data are processed to Level 1.5, i.e. they are corrected for radiometric and geometric non-linearity before onward distribution to the user. Two types of frequencies are divided into data:

- Archived data, required to EUMETSAT, are assembled and delivered with a time step of 15 minutes
- Real time data are collected every 5 minutes

Both type of data are distributed with the appropriate ancillary information allowing the user to compute the geographical position and radiance of any pixel.

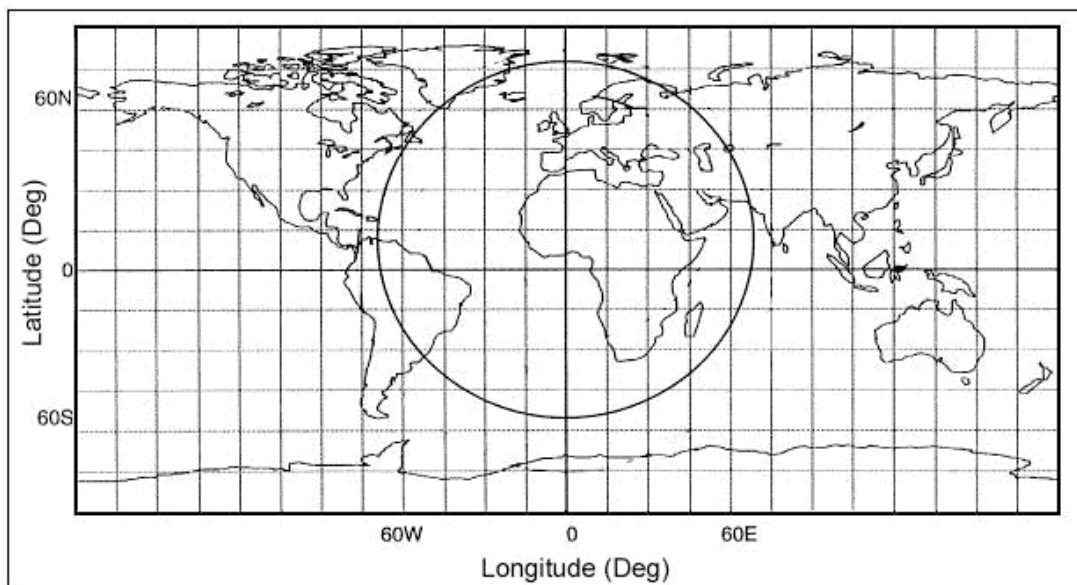

**Figure 1.** The figure shows the spatial coverage of a single image from MSG-SEVIRI.

The spatial coverage of imager includes the whole Europe, Africa and locations at which the elevation to the satellite is equal or greater than  $10^\circ$  (Figure 1). The various channels provide measurements with a resolution of 3 km at the sub-satellite point. The High Resolution Visible (HRV) channel provides

measurements with a resolution of 1 km. This instrument collects an image every 5 minutes (considering both MSG-1 and MSG-2) and sends it in compressed files of about 100Mb. Data are sent in archives composed of small files corresponding to thin stripes sent simultaneously for each band (Figure 2 and Figure 3).

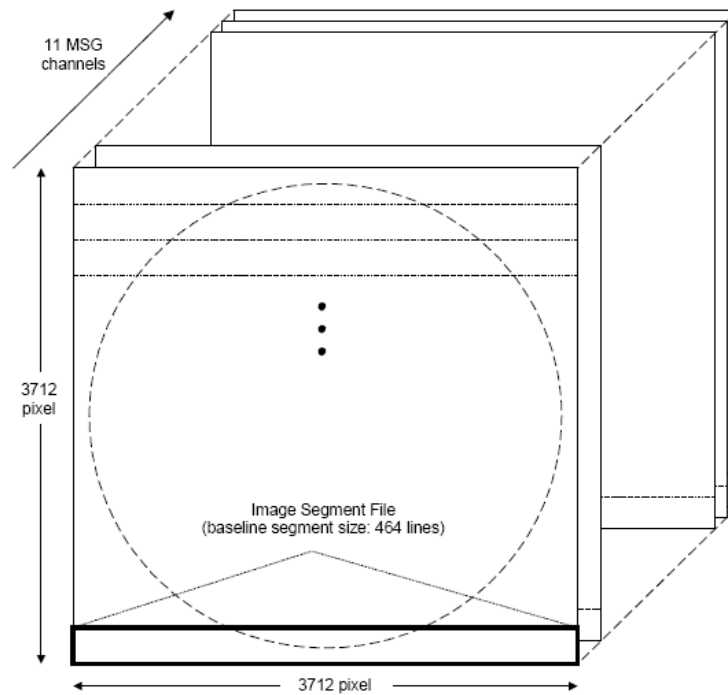

**Figure 2.** Schema of SEVIRI dissemination data format. The first 11 bands are composed of frame of 3712x3712pixels which are divided in stripes sent simultaneously.

## 2. Data processor overall description

The system, described in the following, is dedicated to the pre-processing, calibration, co-registration and storing of MSG-SEVIRI data. The MSG data processor collects different stripes of data coming from MSG-SEVIRI and creates calibrated data files for the desired region. The overall architecture of the system has been developed in order to be used both for the continuous reception of data or to extract information from a single SEVIRI frame. The underlying MySQL database (<http://dev.mysql.com/>) keeps trace of the arrived files, the co-registration coefficients, the processing status and finally stores resulting images. MySQL has been chosen due to its flexibility in creating, inserting and querying data according to the user specific needs. Acting on system and by using the stored coefficients it is moreover possible to run further processing tuning the co-registration phase and cloud masking algorithm. The software is developed using JAVA language (<http://java.sun.com/>); the global image deformatting process is performed by mean of meteosatlib software (<http://meteosatlib.sourceforge.net/>) finalized to the processing of images received by a Primary Data User Station; some additional libraries and open source packages are also used (<http://www.unidata.ucar.edu/software/netcdf/>, <http://www.imagemagick.org/script/index.php>).

## 3. Archives decompression

The offline archives are composed of compressed tar files. The wavelet decompression method has been made by using EUMETSAT software (PublicDecompWT © 2004) provided under licence by EUMETSAT. These are uncompressed in a working directory. Each archive is then verified by checking that the contained files correspond to the file list written in the associated readme.txt file (provided by EUMETSAT).



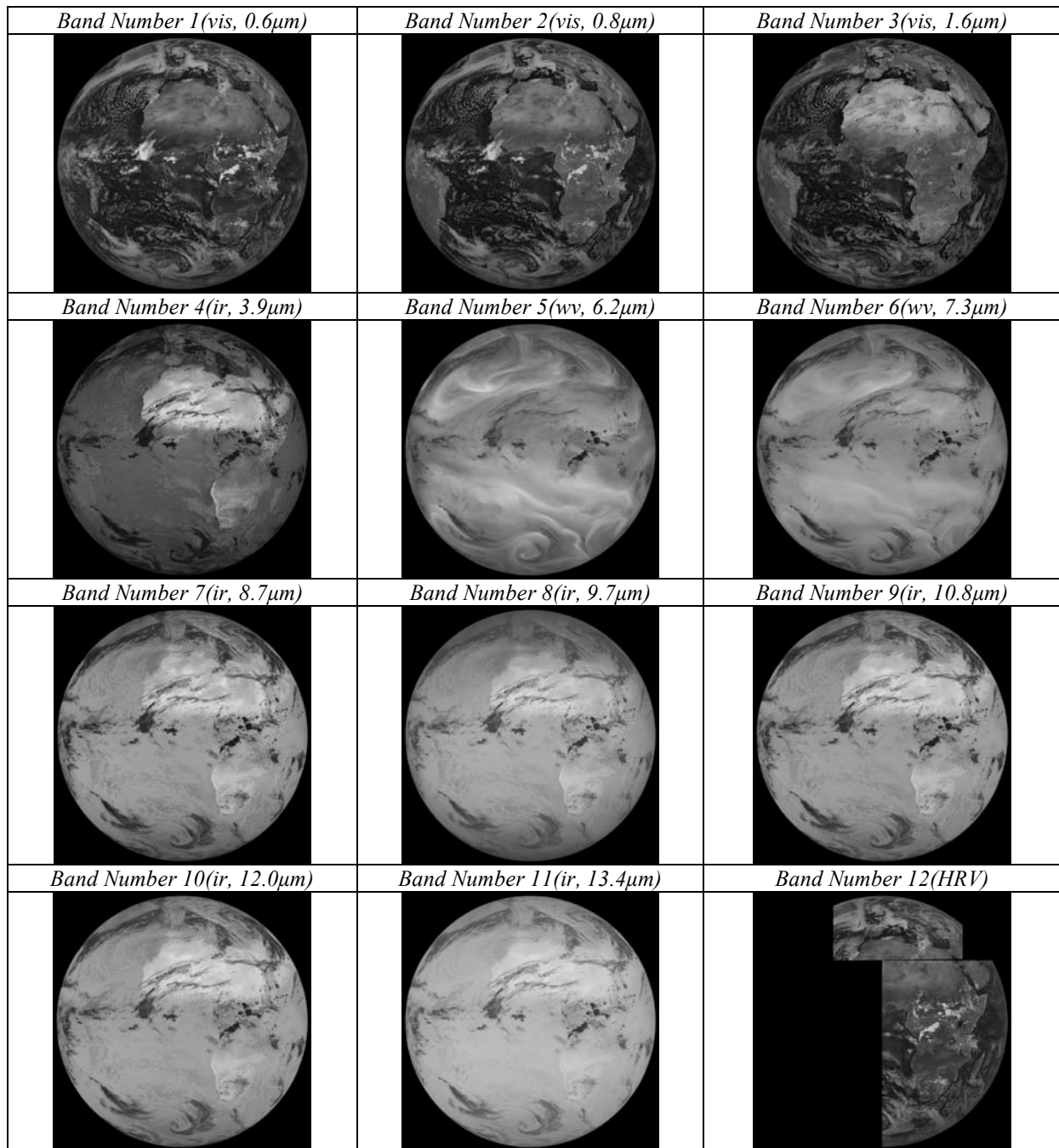

**Figure 3.** SEVIRI Spectral Channels - SEVIRI data consist of geographical arrays of various sizes of image pixels, each pixel containing 10 data bits, representing the received radiation from the earth and its atmosphere in 12 spectral channels.

#### 4. Co-registration

After decompression, subsequent images are co-registered in order to fix possibly misalignment between frames. This operation consists on the search of a set of shift coefficients with which translates one image in order to making it over imposed to the previous. Starting from an initial image, nominally 'reference', we shift the subsequent which will became the new reference and so on with a recursive operation. If the archive lacks of some image, the process stops.

We define a regular control grid  $S(i,j)$  for the images and consider a small window centred around each pixel  $(i,j)$  in the secondary image, called *secondary window*. In the reference image we consider a larger window around pixel  $(i,j)$  called *reference window*.

If  $f$  and  $g$  are pixel arrays associated respectively to reference and secondary windows, the correlation coefficient  $r(x, y)$  can be defined as:

$$r(x, y) = \frac{\sum_{k,l} (f(k+x, l+y) - \bar{f}_{sw})(g(k, l) - \bar{g})}{\sqrt{\left[ \sum_{k,l} (f(k+x, l+y) - \bar{f}_{sw})^2 \right] \left[ \sum_{k,l} (g(k, l) - \bar{g})^2 \right]}} \quad [\text{Eq. 1}]$$

where all summations are performed over secondary window index ranges. Overbar denotes averaging operator and  $\bar{f}_{sw}$  is the average of the reference window region under the secondary window. The correlation coefficient allows the identification of common features between the reference window and the secondary window. The location of maximum gives the shift between the centres of the two windows and then the amount of correction to be applied. This estimation is performed on every couple of images, refining subsequently the correlation coefficient. We have chosen differently from [Santantonio et al.,] in order to consider only a first order shift because the overlap between subsequent frames for MSG is assumed to be very good on principle. The presence of clouds can highly affect the result obtained by this formula; in fifteen minutes interval, clouds maintain their shape but translate considerably in position. The moved cloud in the second image strongly correlates with the cloud itself in the first image (Figure 4).

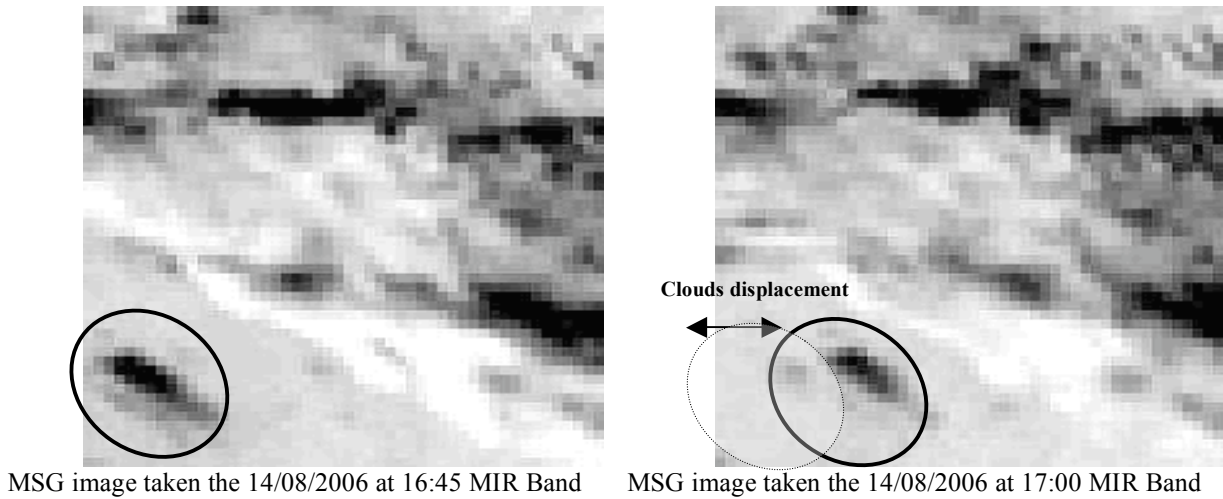

**Figure 4.** Definition of clouds displacement used to define the shift entity generated among an image and the subsequent.

This strong correlation can affect the global computation of mean shifts. In order to avoid this unwanted behaviour we filter out the clouds contribution by mean of a cloud masking based on a threshold algorithm. This consists in the following steps (Figure 5):

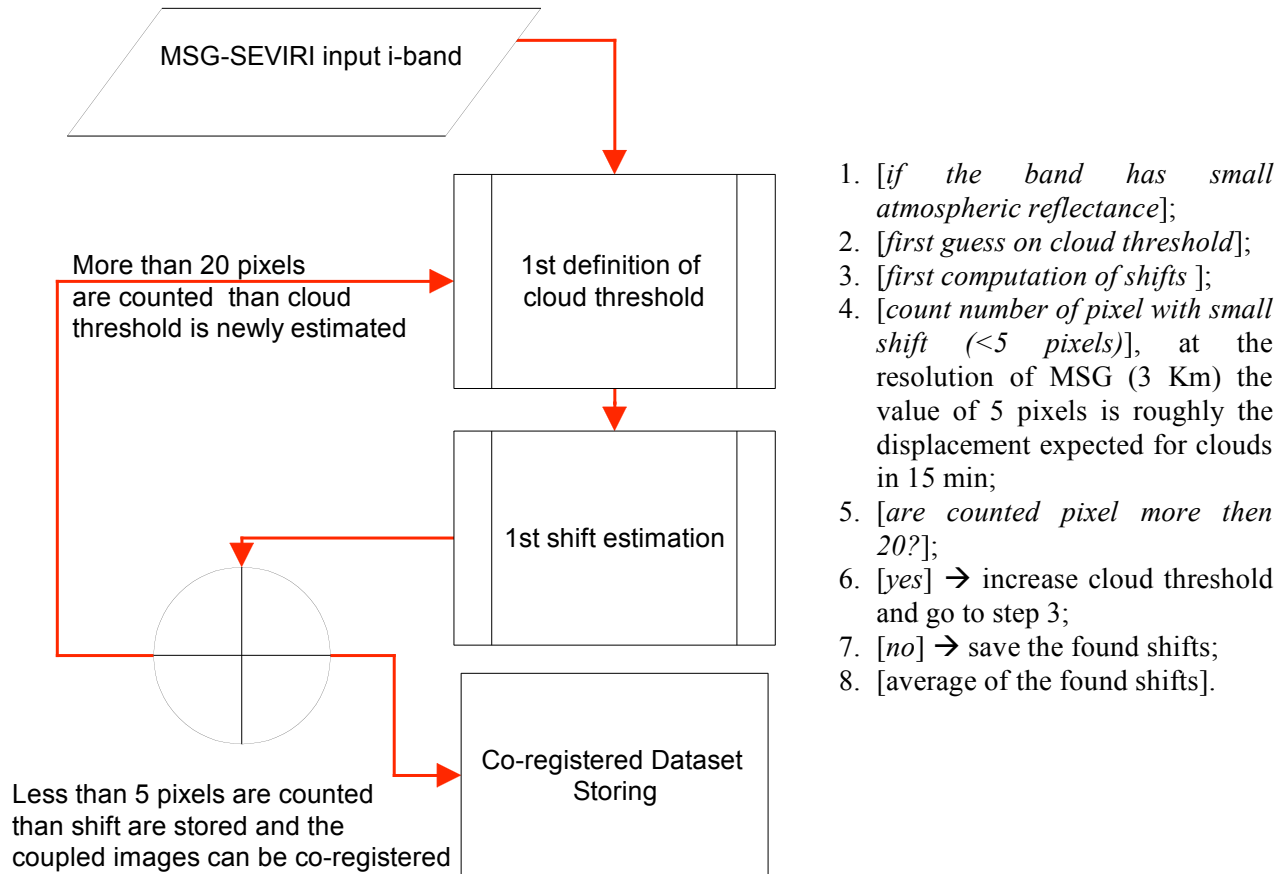

**Figure 5.** Flow diagram indicating the main steps for the co-registration steps and shift estimation storing.

The first assumption in step 1 is essential in order to reach a reasonable result, because there are some bands which contain only clouds. In particular we have excluded visible bands at: (0.6; 0.8; 0.62; 0.73)  $\mu\text{m}$  and the 1.6  $\mu\text{m}$  band. The first guesses on threshold to be applied are chosen manually by visual inspection of the cloud filter result. The counting of the accepted points number (step 4) permits to evaluate if the cloud masking has been effective or not. At the end of the process all the evaluated shifts for each bands are averaged and the averages used for all the bands. This is reasonable being all the band taken with the same instrument. The shift coefficients are stored in the DB and can be verified after processing and parameter corrected and tuned. The main important parameters those can be changed by user are:

- reference window dimension;
- initial cloud threshold;
- maximum accepted shift between subsequent images.

After the co-registration phase, user selected regions are extracted from the processed images and stored into the DB. The images are generated in their native units ( $\text{mW}/(\text{m}^2 \cdot \text{sr} \cdot \text{cm}^{-1})$ ) and converted in a more friendly radiance units [ $\text{W}/(\text{m}^2 \cdot \text{sr} \cdot \mu\text{m})$ ] for all the bands. (Figure 6).

## Conclusions

A SW dedicated to the pseudo NRT MSG-SEVIRI data has been developed and presented in this report.

This procedure has the capability to produce calibrated radiance value every 15 minutes, with the same time rate of collected native data. The updating frequency corresponds to the processing time needed for the

generation of a whole dataset composed by 11 channels every 15 minutes over the hemisphere looked by the sensor.

This procedure will be able to process “on demand” level1.5 HRIT data, kindly provided, at no cost for Research Institute and for non operational service, by the EUMETSAT consortium which is in charge to acquire, store and delivery data generated by the present mission.

This SW has been developed within the activities of the ESA Contract: n° 19494/05/IL-G.

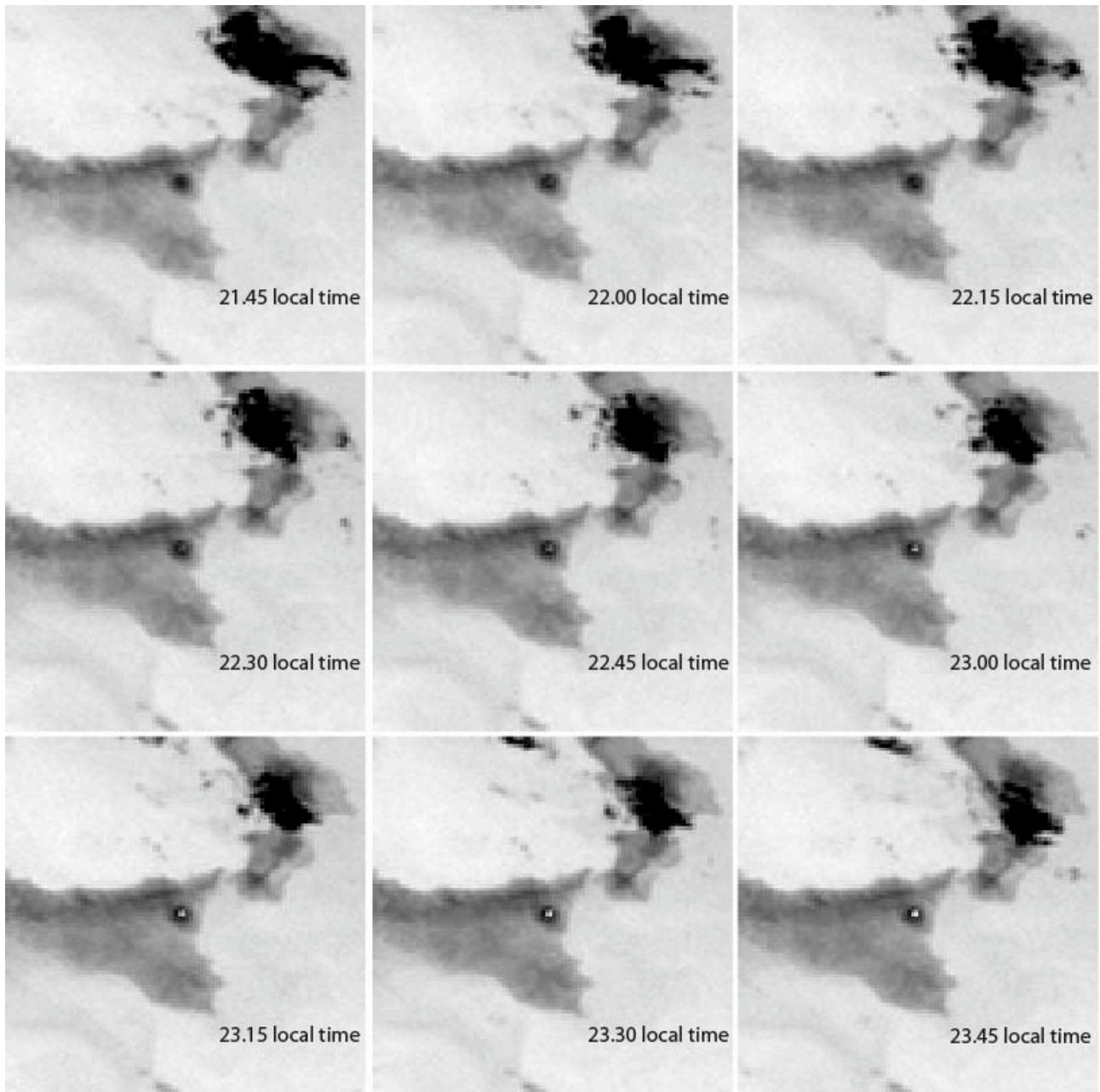

**Figure 6.** MSG-SEVIRI MIR channel. Example of resized images sample every 15 minutes covering East Sicily and South Calabria area. Radiances value are expressed in  $W/m^2 \cdot sr \cdot \mu m$ .

### Acknowledgements

The authors would thanks EUMETSAT for the data availability and ESA which found the project. Moreover Antonella Canestro and Agostino Fiorani for their support.

## References

EUMETSAT, <http://www.eumetsat.int/Home/index.htm>

ImageMagick <http://www.imagemagick.org/script/index.php>

Meteosatlib (<http://meteosatlib.sourceforge.net/>) written by Graziano Giuliani: Laboratory for Meteorology and Environmental Modelling (LaMMA – Tuscany Region), Florence, Italy

MySQL Database (<http://dev.mysql.com/>) (2005) MySQL 5.0 User manual MySQL Community Server 5.0.27

NetCDF (Network Common Data Form), <http://www.unidata.ucar.edu/software/netcdf/>

Santantonio, N. Bartoloni, A. Bini, A. Esposito, P.G. Lorenzini, S. (2002) A multi-parameter retrieval approach to HypSEO spectral and radiometric calibration. Geoscience and Remote Sensing Symposium, 2002. IGARSS '02. 2002 IEEE International

Sun Microsystems, <http://java.sun.com/>



**Coordinamento editoriale e impaginazione**

Centro Editoriale Nazionale | INGV

**Progetto grafico e redazionale**

Laboratorio Grafica e Immagini | INGV Roma

© 2010 INGV Istituto Nazionale di Geofisica e Vulcanologia

Via di Vigna Murata, 605

00143 Roma

Tel. +39 06518601 Fax +39 065041181

**<http://www.ingv.it>**



**Istituto Nazionale di Geofisica e Vulcanologia**